

EQ SERIES[®]

High Performance Commercial Pump



Installation and User's Guide

IMPORTANT SAFETY INSTRUCTIONS
READ AND FOLLOW ALL INSTRUCTIONS
SAVE THESE INSTRUCTIONS

Customer Service

If you have questions about ordering Pentair replacement parts, and pool products, please use the following contact information:

Customer Service (8 A.M. to 5 P.M. — Eastern and Pacific Times)

Phone: (800) 831-7133

Fax: (800) 284-4151

Technical Support

Sanford, North Carolina (8 A.M. to 5 P.M. — Eastern Time)

Phone: (919) 566-8000

Fax: (919) 566-8920

Moorpark, California (8 A.M. to 5 P.M. — Pacific Time)

Phone: (805) 553-5000 (Ext. 6312)

Fax: (805) 553-5515

Web site

visit www.pentairpool.com to find information about Pentair products



© 2005 Pentair Water Pool and Spa, Inc. All rights reserved.

This document is subject to change without notice.

1620 Hawkins Ave., Sanford, NC 27330 • (919) 566-8000

10951 West Los Angeles Ave., Moorpark, CA 93021 • (805) 553-5000

Trademarks and Disclaimers. The *Pentair Pool Products logo* and EQ Series are registered trademarks of Pentair Water Pool and Spa, Inc. Other trademarks and trade names may be used in this document to refer to either the entities claiming the marks and names or their products. Pentair Water Pool and Spa, Inc. disclaims any proprietary interest in trademarks and trade names other than its own.

Table of Contents

Important Safety Precautions	ii
Section 1: Introduction	1
EQ Series Pump Overview	1
General Features	2
Section 2: Installation	3
Installing the EQ Series Pump	3
Mechanical Installation	3
Pressure Testing	5
Section 3: Electrical Requirements	7
Electrical Requirements and Field Wiring	7
Section 4: Initial Operation of Pump	9
Priming the EQ Series Pump	9
Section 5: Maintenance	11
Cleaning the Strainer Basket	11
Preventative Maintenance	12
Section 6: Servicing	13
Disassembling	14
Assembling	15
Section 7: Troubleshooting	16
Section 8: Replacement Parts	17
Section 9: Pump Technical Data	18
Pump Curves	18
Engineering Specifications	19
Dimensional Data	20

IMPORTANT SAFETY PRECAUTIONS



Important Notice:

This guide provides installation and operation instructions for the EQ Series Pump. Consult Pentair Water with any questions regarding this equipment.

Attention Installer: This guide contains important information about the installation, operation and safe use of this product. This information should be given to the owner and/or operator of this equipment after installation or left on or near the pump.

Attention User: This manual contains important information that will help you in operating and maintaining this pump. Please retain it for future reference.



WARNING — Before installing this product, read and follow all warning notices and instructions which are included. Failure to follow safety warnings and instructions can result in severe injury, death, or property damage. Call (800) 831-7133 for additional free copies of these instructions.

Consumer Information and Safety

The EQ Series pumps are designed and manufactured to provide many years of safe and reliable service when installed, operated and maintained according to the information in this manual and the installation codes referred to in later sections. Throughout the manual, safety warnings and cautions are identified by the “” symbol. Be sure to read and comply with all of the warnings and cautions.



DANGER — **Risk of electrical shock or electrocution.**



This pool pump must be installed by a licensed or certified electrician or a qualified pool serviceman in accordance with the National Electrical Code and all applicable local codes and ordinances. Improper installation will create an electrical hazard which could result in death or serious injury to pool users, installers, or others due to electrical shock, and may also cause damage to property.

Always disconnect power to the pool pump at the circuit breaker before servicing the pump. Ensure that the disconnected circuit is locked out or properly tagged so that it cannot be switched on while you are working on the pump. Failure to do so could result in serious injury or death to serviceman, pool users or others due to electric shock.



WARNING — Do not operate the pump until you have read and understand clearly all the operating instructions and warning messages for all equipment that is a part of the pool circulating system. The following instructions are intended as a guide for initially operating the pump in a general pool installation, however each installation may have unique conditions where the starting procedure could be different. Failure to follow all operating instructions and warning messages can result in property damage or severe personal injury or death.



WARNING — To reduce the risk of injury, do not permit children to use this product unless they are closely supervised at all times.

IMPORTANT SAFETY PRECAUTIONS (continued)

 **WARNING** — Never exceed the maximum operating pressure or temperature limits of the system components. Pumps installed with the EQ Strainer Pot Assembly should not be tested at a pressure that exceeds the value written on the EQ Strainer Pot. See the Owner's Manual that accompanies that product for more instructions. Ensure that pressures higher than those required in the pressure test cannot inadvertently be applied to the circulation system. This may require the use of a pressure regulator between the water supply and the circulation system.

Changes in temperature or barometric pressure can cause the internal test pressure to increase or decrease over time once the system is isolated. A pressure relief device should be installed that would prevent the pressure from exceeding the intended test pressure. Exceeding these limits could result in a component failing under pressure. This instantaneous release of energy can cause failed components to be accelerated to high velocities and to travel distances of 100 feet or more. These components could cause severe personal injury or death if they were to strike a person.

 **WARNING** — Due to the potential risk that can be involved it is recommended that the pressure test be kept to the minimum time required by the local code. Do not allow people to work around the system when the circulation system is under pressure test. Post appropriate warning signs and establish a barrier around the pressurized equipment. If the equipment is located in an equipment room, lock the door and post a warning sign.



Never attempt to adjust any closures or lids or attempt to remove or tighten bolts when the system is pressurized. These actions can result in a separation or failure of system components. This instantaneous release of energy can cause components to be accelerated to high velocities and to travel distances of 100 feet or more. These components could cause severe personal injury or death if they were to strike a person.

 **CAUTION** — This pump is for use with permanently installed pools and may also be used with hot tubs and spas if so marked. Do not use with storable pools. A permanently installed pool is constructed in or on the ground or in a building such that it cannot be readily disassembled for storage. A storable pool is constructed so that it may be readily disassembled for storage and reassembled to its original integrity.

IMPORTANT SAFETY PRECAUTIONS (continued)

General Installation Information

⚠ WARNING — Pumps improperly sized or installed or used in applications other than for which the pump was intended can result in severe personal injury or death. These risks may include but not be limited to electric shock, fire, flooding, suction entrapment or severe injury or property damage caused by a structural failure of the pump or other system component.

⚠ WARNING — The pump can produce high levels of suction within the suction side of the plumbing system. These high levels of suction can pose a risk if a person comes within the close proximity of the suction openings. A person can be seriously injured by this high level of vacuum or may become trapped and drown. It is absolutely critical that the suction plumbing be installed in accordance with the latest national and local codes for swimming pools.



- These instructions contain information for a variety of pump models and therefore some instructions may not apply to a specific model. All models are intended for use in swimming pool applications. The pump will function correctly only if it is properly sized to the specific application and properly installed.
- The pump is available with or without a specially designed strainer pot assembly. If a suction strainer pot assembly is to be provided, it should comply with NSF-50 standards. Pumps without the strainer pot assembly are not self-priming and must be installed so that the pump is always flooded with water. If the pump is to be installed without a strainer pot, plumbing suction inlets must prevent debris larger than ¼ in. in diameter from being drawn into the pump.
- Pumps installed with the specially designed strainer pot assembly are self-priming at heights up to 10 feet depending on the specific installation.

Section 1

Introduction

EQ Series® High Performance Commercial Pump Overview

The EQ Series pumps deliver extraordinary performance in every key aspect. They're built to last, of course, and are also built to be incredibly efficient, quiet, lightweight and corrosion-resistant. All of this adds up to a pump that is highly cost effective and suited for a wide range of commercial water applications.

At the heart of the EQ's extraordinary performance is its unique impeller design. It provides two significant benefits. First, it means more efficient performance — the EQ pump moves more water more quickly than comparable pumps. And secondly, it means the pump's motor doesn't have to work as hard and, as a result, runs cooler and lasts considerably longer.

What's more, the Pentair EQ pump has been through a rigorous design, development and testing program so you know it's built to handle the toughest commercial applications for years to come.

Available in single and three-phase, 50 and 60 Hz models, the EQ sets the new standard for performance in pumps. No one else in the industry has made a plastic injection-molded pump with performance like this for pool and water applications.



EQ Series Pump

Patent Pending

General Features

- EQ Series = Energy Efficient and Quiet
- Designed in every detail for maximum efficiency
- The only non-corrosive, all-plastic pump designed exclusively for the commercial pool and water applications market
- The EQ impeller features an exclusive design that provides true breakthrough performance
- Lower load due to efficient impeller design means longer motor life
- Cam and Ramp™ lid design with clear lid for added convenience in servicing

Additional Features:

- Closed coupled for quiet stable flow operation
- Lightweight
- 6" suction and 4" discharge with strainer pot
- Closed impeller for longer motor life
- Heat-resistant seal operates at up to 150° Fahrenheit
- Bolt-on strainer pot
- Easy one-man installation
- Self-priming pump
- NSF-Listed
- Models available for water feature applications

Section 2

Installation

The following general information describes how to install the EQ Series pump.

Note: Before installing this product, read and follow all warning notices and instructions starting on page ii.

Installing the EQ Series Pump

Only a qualified service person should install the EQ Series pump.

Mechanical Installation and Pressure Testing

Mechanical Installation

1. Carefully remove the pump unit and strainer pot assembly, if included, from its shipping package.
2. The pump will perform best when the suction and return head losses (Total Dynamic Head (TDH)) of the pool system have been carefully determined and the correct pump model selected to fit these requirements. A pump should be selected to operate near the center of its Performance Curve with as high an efficiency as possible. It is also important that the Net Positive Suction Head Available (NPSHA) be greater than the Net Positive Suction Head Required (NPSHR) at the design flow rate.
3. If it is not possible to determine accurate suction and discharge head losses (Total Dynamic Head (TDH)), conservative plumbing practices should be strictly adhered to. This would include installing the pump as close to the pool as possible and at approximately the same level as the pool water level. (See [page iv.](#), **General Installation Information**, regarding when a strainer pot assembly is required.) Use large diameter pipe especially on the suction line to keep flow velocities at or below 6 feet per second (fps). Flow velocities in the return plumbing should not exceed 10 fps. Also keep elbows and tees to a minimum. Installations where the pump is going to be installed more than 10 feet below or 5 feet above the pool water level must be evaluated by an experienced professional to ensure that the pump will function correctly.
4. A solid flat foundation should be provided to support the pump. The area should be well drained so that the pump motor will not be flooded under any circumstances. Ensure that adequate space and lighting around the pump is provided for routine maintenance activities.

NOTE

Do not install the pump motor within 5 feet of the inside walls of the pool wall unless the pump bears the UL listing mark. UL listed pumps may be installed within 5 feet of the inside walls of a swimming pool, spa or hot tub only if a solid copper bonding conductor not smaller than No. 8 AWG is connected from a bonding lug wire connector on the motor to all metal parts of the swimming pool, spa or hot tub structure and to all electrical equipment, metal conduit, and metal piping within 5 feet of the inside walls of the swimming pool, spa or hot tub.

5. It is good practice for most installations to install a valve on both the suction and return line so that the pump can be isolated for routine maintenance. However, a valve, elbow or tee installed in the suction line should be no closer to the front of the pump than 5 times the suction line pipe diameter. (*i.e.* 6 in. pipe requires a 30 in. straight run in front of the suction inlet of the pump.)

Mechanical Installation, cont.'d.

6. Assemble the strainer pot assembly, if included, to the pump. Be sure to install the O-Ring (included with the strainer pot assembly) over the protruding plastic ring on the front of the pump housing before mounting the strainer pot. Properly position the strainer pot to the housing and secure in place using the 8 large flange bolts and washers included with the strainer pot assembly. These bolts should not be over tightened as this could damage the pump. Proper technique is to lightly snug each bolt with a wrench. A squealing sound during tightening of the bolts indicates that the bolts are being excessively tightened.
7. Place the pump in its final location and ensure that the mating flanges of the suction and discharge piping are in line and parallel to the flanges on the pump. Resolve any problems with misalignment before bolting the flanges to the pump.
8. The pump may be secured to bolts buried in the concrete by using the holes on the outside of the motor supports.
9. Ensure that the flange gasket is properly positioned between the suction flange of the pump and the flange of the suction piping. Use only high quality rubber, full diameter flange gaskets with holes for the bolts to pass through. It may be necessary to hold the gasket in place with either silicone or two or three drops of a cyanoacrylate (super glue) material. Do not use any other grease or glue as they may contain chemicals that could attack the plastic material. Install the flange bolts hand tight on the suction side of the pump.

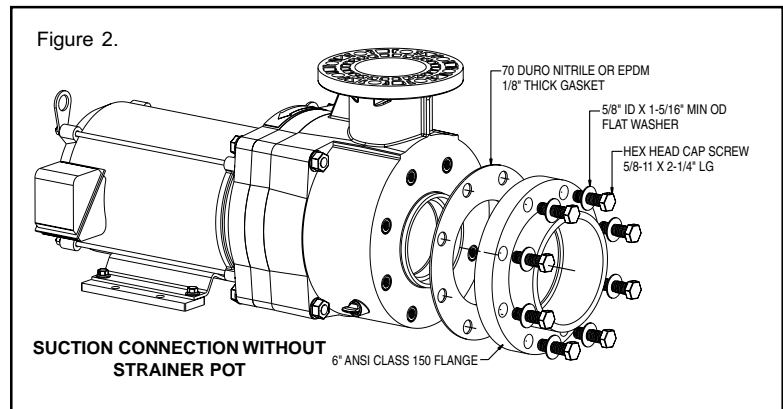
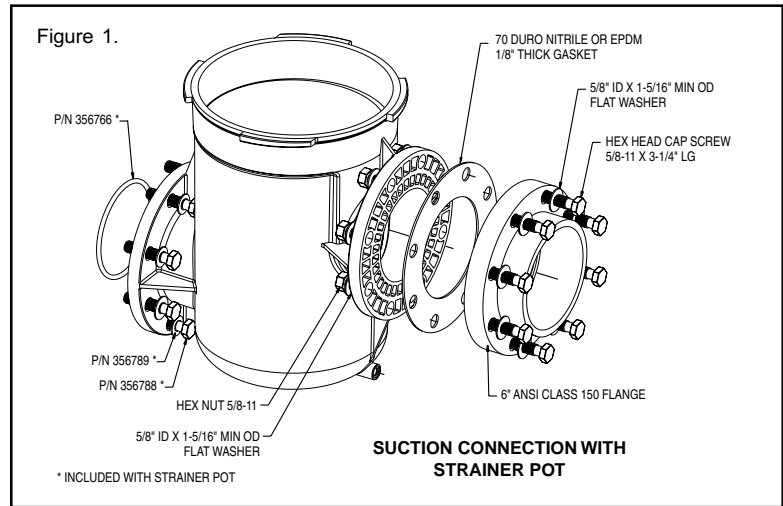



- CAUTION** — On installations where the pump is installed without a strainer pot, use only 6 in. Schedule 40 PVC pipe when making the final flange connection. Do **NOT** use Schedule 80 Pipe, as this can cause interference with the pump housing.
- CAUTION** — Use large diameter flat washers between the hex nut and the pump flanges to properly distribute the clamping forces on the flange. Tighten the flanges to 20 ft.-lb. unless otherwise specified by the flange manufacturer. If it is not possible to use a torque wrench then care should be taken not to over tighten the flange bolts. Failure to follow the above instructions can result in damaging the pump flange.
10. Properly insert the flange gasket on the discharge port of the pump. Install the flange bolts hand tight on the discharge flange connection.
 11. Inspect both the suction and flange connection to ensure alignment remains acceptable. Take any corrective action before tightening the flange bolts to the required torque.

- CAUTION** — Suction and discharge piping must be supported by an appropriate system of supports or hangers. Inadequately supported pipe can cause excessive loads to be transmitted to the pump resulting in a structural failure of the pump that could result in flooding and property damage.

Pressure Testing

Certain local codes require that the circulation system be pressure tested with a proof pressure before being commissioned into service or before allowing construction to progress to the next stage.

 **WARNING** — Improperly pressure testing a circulation system can involve significant risk of property damage or severe personal injury or death. Circulation systems store energy when pressure tested due to the elastic nature of the materials used in construction and due to the compressibility of air that may be contained in the system. The instructions below should be considered a guide only. Each installation should be considered a unique situation that should be carefully investigated for risk.

 **WARNING** — Never test this equipment with air pressure even if specified by the local code. Even low levels of air pressure result in tremendous storage of energy that can instantaneously be released if a system failure occurs. This instantaneous release of energy can cause failed components to be accelerated to high velocities and to travel distances of 100 feet or more. These components could cause severe personal injury or death if they were to strike a person.

1. Understand the local code. The intent of the code may be to ensure that the piping system with its many bonded joints is leak free. Piping systems typically have a higher pressure capability than the other system components such as the pump or filter. Do not pressure test the pump unless the code specifically requires this.
2. Verify that each component in the system is designed to meet the local code test pressure. Most components should be marked with a maximum operating pressure. If a component is not marked consult the Owner's Instructions that came with the component or consult the manufacturer.
3. Verify that the pressure test will be conducted within the operating temperature listed on the components that make up the circulation system. If no maximum operating temperature is listed then it may be necessary to review the owner's manual or contact the manufacturer for this information. It is common practice for plastic components to be pressure rated at 72 degrees F. and then derated for temperatures greater than this.
4. Use only a high quality pressure gage that is certified to be accurate for the pressure for which the test is going to be conducted. Do not rely on the pressure gage included with the filtration system as it may not be sufficiently accurate to conduct a pressure test for the system. Please note that the pressure in the system will vary depending on where the pressure is taken due to the weight of the water.
5. Ensure that all air will be evacuated from the system when the water pressure is applied to the system. This will require that all air bleeders on any equipment are open. It also may be necessary to remove some lids or covers on system equipment such as the pump strainer lid to prevent air from being trapped in the system. In addition, there may be other areas of the circulation system where air may be trapped. Do not connect water pressure to the system until you are certain that air will be totally evacuated.
6. Determine the appropriate location in the system to apply the test water pressure. Consider the place in the system that will best ensure that all air will be displaced when water is introduced.

Pressure Testing, cont'd.

 **WARNING** — Never exceed the maximum operating pressure or temperature limits of the system components. Pumps installed with the EQ Strainer Pot Assembly should not be tested at a pressure that exceeds the value written on the EQ Strainer Pot. See the Owner's Manual that accompanies that product for more instructions. Ensure that pressures higher than those required in the pressure test cannot inadvertently be applied to the circulation system. This may require the use of a pressure regulator between the water supply and the circulation system.

Changes in temperature or barometric pressure can cause the internal test pressure to increase or decrease over time once the system is isolated. A pressure relief device should be installed that would prevent the pressure from exceeding the intended test pressure. Exceeding these limits could result in a component failing under pressure. This instantaneous release of energy can cause failed components to be accelerated to high velocities and to travel distances of 100 feet or more. These components could cause severe personal injury or death if they were to strike a person.

7. Slowly apply the water pressure and allow the water to flow out all of the openings intended for air to escape. Close the openings beginning at the lowest level first and progressing to the highest level. Do not close any opening until you are sure that air is completely out of that part of the system.
8. Allow the pressure to slowly build once all of the air openings are closed. Close the valve between the water supply and circulation system to isolate the system from the supply pressure.
9. Monitor the system pressure for a few minutes to ensure that it is stabilized.

 **WARNING** — Due to the potential risk that can be involved it is recommended that the pressure test be kept to the minimum time required by the local code. Do not allow people to work around the system when the circulation system is under pressure test. Post appropriate warning signs and establish a barrier around the pressurized equipment. If the equipment is located in an equipment room, lock the door and post a warning sign.

Never attempt to adjust any closures or lids or attempt to remove or tighten bolts when the system is pressurized. These actions can result in a separation or failure of system components. This instantaneous release of energy can cause components to be accelerated to high velocities and to travel distances of 100 feet or more. These components could cause severe personal injury or death if they were to strike a person.

10. It is normal for the test pressure to drift down slightly during the first few minutes as the circulation system expands under pressure.
11. If the system pressure continues to fall, then bleed off the remaining water pressure in the circulation system and inspect the system for leaks. Look for water on the floor and feel around joints for moisture.
12. Ensure the system is not under pressure before attempting any system adjustments or repairs.
13. Repeat the pressurization sequence once the system leaks have been corrected.

Section 3

Electrical Requirements

This section describes how to secure and wire the EQ pump.

Electrical Requirements and Field Wiring

NOTE

Do not install the pump motor within 5 feet of the inside walls of the pool wall unless the pump bears the UL listing mark. UL listed pumps may be installed within 5 feet of the inside walls of a swimming pool, spa or hot tub only if a solid copper bonding conductor not smaller than No. 8 AWG is connected from a bonding lug wire connector on the motor to all metal parts of the swimming pool, spa or hot tub structure and to all electrical equipment, metal conduit, and metal piping within 5 feet of the inside walls of the swimming pool, spa or hot tub.

 **CAUTION** — This pump is for use with permanently installed pools and may also be used with hot tubs and spas if so marked. Do not use with storable pools. A permanently installed pool is constructed in or on the ground or in a building such that it cannot be readily disassembled for storage. A storable pool is constructed so that it may be readily disassembled for storage and reassembled to its original integrity.

 **WARNING** — **Risk of electrical shock or electrocution.**



This pool pump must be installed by a licensed or certified electrician or a qualified pool serviceman in accordance with the National Electrical Code and all applicable local codes and ordinances. Improper installation will create an electrical hazard which could result in death or serious injury to pool users, installers, or others due to electrical shock, and may also cause damage to property.

Always disconnect power to the pool pump at the circuit breaker before servicing the pump. Failure to do so could result in death or serious injury to serviceman, pool users or others due to electric shock.

1. Ensure that the electrical service is disconnected, properly tagged and locked out before working on the pump.
2. Carefully review the motor label. Take note of the important nameplate information such as volts, amps, phase, HP and code. Most pump models may be field connected so that they can operate on two different voltage circuits. Use extreme care in reviewing the motor wiring diagrams and always verify the voltage of the electrical supply circuit.
3. Carefully review the electrical supply circuit to ensure that it is adequate to meet the pump requirements identified on the motor nameplate. An electrical code letter is identified on the motor nameplate that identifies the load characteristics of the motor.

Electrical Requirements and Field Wiring, cont'd.

⚠ CAUTION — Some single-phase pumps may contain an internal thermal protector designed to temporarily stop the pump if the motor exceeds a preset temperature. The pump will automatically restart when the motor temperature falls to a preset limit. Always disconnect power before working on the pump to eliminate the possibility that the pump could start unexpectedly.

Three-phase pumps do not contain an internal thermal protector and must be externally protected by an appropriately sized protective device commonly referred to as a starter. Improper sizing of the starter can result in the motor being destroyed or in frequent tripping of the starter.

4. It is important that all portions of the electrical circuit including the conductors that connect the electrical panel to the pump motor are properly sized based on the nameplate information on the pump.
5. Following the National Electrical Code and any local electrical codes connect the grounding conductor and electrical supply conductors to the motor. Ensure that the pump is properly grounded per the above codes utilizing the grounding screw identified in the terminal box of the pump motor.
6. It will be necessary to confirm that the rotation of the motor is in the correct direction on all three-phase pump units and on certain single-phase pump units. Check wiring diagram to determine if motor can be field wired to rotate in both directions. Checking rotation by energizing the pump for one second and then watching the rotation through the back of the motor as it coasts to a stop. Ensure that the rotation matches the direction arrow on the pump. Operating a pump with the incorrect rotation can cause many problems including poor priming, diminished water flow, excessive noise, overloading of the motor and premature failure of the pump.

⚠ CAUTION — Always fill the pump with water before energizing the pump motor. Operating the pump without water can damage the pump seal within a few seconds.

Section 4

Initial Operation of Pump

This section describes how to prime the EQ pump.

 **WARNING** — Do not operate the pump until you have read and understand clearly all the operating instructions and warning messages for all equipment that is a part of the pool circulating system. The following instructions are intended as a guide for initially operating the pump in a general pool installation, however each installation may have unique conditions where the starting procedure could be different. Failure to follow all operating instructions and warning messages can result in property damage or severe personal injury or death.

1. Relieve any pressure that may be trapped in the circulation system.
2. Open all air relief devices on any equipment in the system.
3. Open the appropriate valves on the suction and discharge plumbing. If the pump is installed below the water level of the pool, water will flow into the pump. If the pump is installed above the water level it will be necessary to fill the strainer pot with water up to the suction pipe connection.

 **WARNING** — The strainer pot may be at a pressure that is higher or lower than the atmospheric pressure. Always open the drain plug on the strainer pot and allow for the pressure to equalize before removing the locking ring. Attempting to remove the locking ring before the pressure is equalized may result in a rapid exchange of pressure. This instantaneous release of energy can cause components to be accelerated to high velocities and to travel distances of 100 feet or more. These components could cause severe personal injury or death if they were to strike a person.

4. Stand clear of all equipment and energize the pump.
5. The pump will experience a temporary unstable condition as water and air flow through the pump. During this unstable condition the pump may be noisy and produce erratic flow. If the pump is below or at water level this temporary unstable condition should last only a few seconds.
6. If the pump is installed above the pool water level then the pump must remove the air from the suction piping. This phase of pump operation is referred to as priming. Pumps that are labeled self-priming have demonstrated in a test laboratory that they can prime when installed 10 feet above the pool water level in a time not exceeding 45 minutes. (*Exception:* Models EQW300 1PH and EQW300 3 PH may require up to 1 hour and 15 minutes to prime to 10 feet. Disconnect power to the pump if it does not prime within the time indicated. A pump that will not prime usually indicates a system problem such as an air leak on the suction side of the pump.)

 **WARNING** — **DO NOT** open the strainer pot if pump fails to prime or if pump has been operating without water in the strainer pot. Pumps operated in these circumstances may experience a build up of vapor pressure and may contain scalding hot water. Opening the pump may cause serious personal injury. In order to avoid personal injury make sure the strainer pot temperature has cooled to room temperature. Carefully remove the drain plug on the strainer pot and allow the pressure to equalize before removing the locking ring.

7. It is important that once the pump has primed and is operating in a stable manner that the voltage be measured at the pump when first put into service. If the electrical supply circuit is inadequate a voltage drop may occur when the pump is operating under load. The pump will operate most efficiently when operated at the nameplate voltage. Operating the pump at more than 10% above or below the voltage listed on the nameplate could result in the pump not operating properly and may damage the pump motor.





Section 5

Maintenance

Cleaning of the Strainer Basket

1. The pump is designed to be maintenance free with the exception of requiring a periodic cleaning of the strainer basket.
2. A routine inspection should be done by visually looking through strainer lid for debris while the pump is in operation. The strainer basket should be cleaned when approximately 25 % blocked. Allowing the strainer basket to become excessively blocked will diminish water flow, reduce pump efficiency, cause cavitation and may damage the basket or other pump components.
3. Disconnect power to the pump before cleaning the basket.
4. Close isolation valves on the suction and discharge lines if necessary to prevent flooding.

 **WARNING** — The strainer pot may be at a pressure that is higher or lower than the atmospheric pressure. Always open the drain plug on the strainer pot and allow for the pressure to equalize before removing the locking ring. Attempting to remove the locking ring before the pressure is equalized may result in a rapid exchange of pressure. This instantaneous release of energy can cause components to be accelerated to high velocities and to travel distances of 100 feet or more. These components could cause severe personal injury or death if they were to strike a person.

 **WARNING** — If the pump has been energized for a period greater than 45 minutes without water flowing through the pump for any reason, the water in the strainer pot may be hot. Attempting to remove the locking ring without removing the drain plug in the pot and allowing the pressure to equalize may result in the hot water rapidly escaping and causing severe personal injury.

5. Open the drain plug in the strainer pot and allow the pressure to completely stabilize.
6. Remove the locking ring and the clear lid from the strainer pot.
7. Remove the basket and dispose of the debris. Use a water hose and soft brush to remove debris blocking the openings in the basket if required.
8. Replace the basket making sure it is properly oriented.
9. Replace the lid, by aligning the four tabs with the tabs on the strainer pot and making sure the O-ring is clean and is properly located in the groove of the lid.
10. Secure the lid in place by tightening the locking ring hand tight only. Do not over tighten the locking ring as that will make removal difficult.

 **WARNING** — It is recommended that only water and a soft cloth be used to clean the lid and other pump components. Cleaners may contain chemicals that could damage or weaken pump components causing them to fail and allowing an instantaneous release of energy. This instantaneous release of energy can cause components to be accelerated to high velocities and to travel distances of 100 feet or more. These components could cause severe personal injury or death if they were to strike a person.

Preventative Maintenance

It may be possible to extend the life of the pump and to prevent a pump down situation by implementing a preventative maintenance program. This may be done by periodically performing a list of activities and recording certain information to be able to spot potential problems before they become serious. It is recommended that these activities be performed after the filter cleaning procedure so that the information will be taken from the same baseline each time. All or part of the following activities could provide the foundation for a preventative maintenance program.

1. Record the time it takes for the pump to prime and come to a stable operating condition. Increased priming times can indicate a problem. See Section 7, Troubleshooting.
2. Observe the sound coming from the pump housing. A substantial change in sound from inside the pump is a clue that something in the circulation system has changed.
3. Observe the sound coming from the motor. Motor bearings rarely fail without first becoming noisy.
4. Observe the temperature of the motor. The motor is designed to carry the pump load without building up excessive heat. An increase in normal operating temperatures may indicate a potential problem. A thermocouple placed at the motor ventilation discharge opening may be used to monitor motor temperature. It normally takes about 1 hour for the motor temperature to stabilize. See Section 7, Troubleshooting.
5. Record any flow and pressure readings on the circulation system meters and gages. See Section 7, Troubleshooting.
6. Record supply voltage and amps. Supply voltage can change throughout the day depending on other electrical loads in the area. Changes in supply voltage will affect the amp draw and water output of the pump.
7. Inspect the floor around the pump to ensure there are no indications of leaks. Address leaks immediately. A mechanical seal leak is indicated by water dripping between the motor and the motor adaptor. A mechanical seal leak can result in a failed motor bearing.
8. Inspect the exterior pump components for any sign of a structural failure. Most structural failures will start with a hairline crack that originates from a corner where two different shapes intersect.
9. Verify that the support brackets or hangars for the suction and discharge piping are continuing to fully support the weight of the piping.

Section 6

Servicing

⚠ WARNING — Risk of electrical shock or electrocution.



This pool pump must be installed by a licensed or certified electrician or a qualified pool serviceman in accordance with the National Electrical Code and all applicable local codes and ordinances. Improper installation will create an electrical hazard which could result in death or serious injury to pool users, installers, or others due to electrical shock, and may also cause damage to property.

Always disconnect power to the pool pump at the circuit breaker before servicing the pump. Ensure that the disconnected circuit is locked out or properly tagged so that it cannot be switched on while you are working on the pump. Failure to do so could result in death or serious injury to serviceman, pool users or others due to electric shock.

Read all servicing instructions before working on the pump.

The pump is designed to allow for quick servicing of any moving parts without disturbing the plumbing connections. The pump can be serviced with the common tools that are in nearly every service persons toolbox. The following sequential instructions are for a complete disassembly in order to replace a failed motor. The same instructions may be used to perform a partial disassembly to replace any internal component, but following all steps will not be required.

⚠ CAUTION — It is recommended that you replace the motor with the Pentair replacement motor as identified in Section 8. This motor has been thoroughly tested to ensure that it will function appropriately with the pump under a wide variety of operating conditions. If you choose to use another replacement motor it is important that the frame type, the HP, the service factor, the voltage, the phase and the motor speed match exactly to that listed on the original motor. Slight differences in these parameters can cause the motor to not fit the pump correctly or cause the motor to fail prematurely.



Disassembly

1. Ensure the electric supply circuit is disconnected and is properly tagged and locked out.
2. Disconnect the line supply conductors and the ground conductor from the motor (1) if the motor is being replaced.
3. Close any valves required to prevent flooding when the pump is disassembled.
4. Review the parts breakdown in Section 8, to understand how the pump components are assembled together.
5. Remove the pump housing (22) drain plug (24) and allow the pump to completely drain.
6. Remove the four 5/8 in. hex nuts (23) that secure the motor end assembly to the front housing (22).
7. If the motor support (2) is bolted to a permanent surface it will be necessary to remove the screws (6) that are securing the motor to the motor support (2) to allow for removal of the motor end assembly.
8. Grasp the motor end assembly and pull backwards. It may be necessary to wiggle the motor assembly from side to side to break free the O-Ring seals inside the pump.
9. Pull the motor end assembly free of the housing (22) so that there is adequate access to the internal components. If desired, the supply conductors can be disconnected and the motor end assembly can be taken to a workbench for easier service.
10. Remove the four screws (20) with washers (18) (19) that secure the diffuser (17) to the seal plate (13).
11. Hold the impeller (15) nose and remove the screw (16) and washers (4) (5) that secure the impeller (15).
12. The impeller (15) is also secured to the shaft by a parallel key . The impeller (15) can be freed from the shaft and key by grasping the outside of the impeller (15) and pulling the impeller (15) away from the motor (1). It is good practice to inspect the impeller (15) to ensure that the vane passageways are open and that no vanes have been substantially broken or worn.
13. Removing the impeller (15) will expose the two pieces of the mechanical seal (14). It will not be necessary to further disassemble the pump if only a seal replacement is required.
14. The seal plate (13) is attached to the motor adaptor (7) by two dowel pins (26). The seal plate (13) can be freed from these dowel pins (26) by grasping the outside of the seal plate (13) and pulling away from the motor wiggling it from side to side if required.
15. Remove the four screws (10) with washers (8) (9) that secure the motor adaptor (7) to the motor (1). These components could cause severe personal injury or death if they were to strike a person.

Assembly

1. Ensure that the two 6 ½ in. long screws (11) with washers (12) are properly inserted into the bottom of the motor adaptor (7) before attaching the motor adaptor (7) to the new motor (1).
2. Properly orient the motor adaptor (7) to the motor (1) and secure in place using the four screws (10) and washers (8) (9).
3. Insert the two dowel pins (26) into the motor adaptor (7).
4. Install the stationary ring of the mechanical seal (14) into the seal plate bore. Ensure that it is fully inserted into the bore with the white surface facing you.

⚠ CAUTION — The mechanical seal is a highly engineered component that must be carefully handled. The contact faces are manufactured to extremely precise tolerances. These faces must be free of all surface dust and debris. Always wash your hands before handling the mechanical seal. Avoid touching the contact faces except for when pressing the seal ring into the bore. Lubricate the rubber portion with a slight amount of soapy water if required to insert it into the bore. Do not use silicone or other lubricants as this can contaminate the seal face. Rinse the seal face if required after assembly to free it of any dirt or debris.

5. Properly orient the seal plate (13), slip it onto the two dowel pins (26) and secure to the motor adaptor (7) by tapping it toward the motor adaptor (7) until there is no clearance between the two parts.
6. Slip the spring portion of the mechanical seal (14) over the motor shaft, being certain that the hard black contact surface is facing the white surface of the stationary seal ring. Use a small amount of soapy water if required to lubricate the rubber of the mechanical seal (14) so that it slips easily over the shaft.
7. Install the shaft key  into the shaft of the motor and then install the impeller (15) over the shaft. It will be necessary to align the keyway in the impeller (15) with the key . Push the impeller (15) as far as possible onto the motor shaft (1).
8. Install the socket head screw (16) with washers (4) (5) to secure the impeller (15). It is important that the screw (16) be tightened securely and that the impeller (15) is fully seated.
9. Apply a light film of silicone grease to the inside diameter of the brass bushing inside the diffuser (17). This film will assist in properly centering the diffuser bushing to the impeller (15) and will reduce the friction should the parts contact during motor start-up. **DO NOT USE ANY OTHER TYPES OF LUBRICANTS.**
10. Install the diffuser (17) over the impeller (15) and secure with the four screws (20), but only hand tight. The diffuser (17) has clearance around the four screws (20) that will allow adjustment of the fit of the diffuser (17) around the impeller (15) nose. Rotate the impeller (15) by hand to ensure that it is free to turn and slowly tighten each of the four screws (20). Verify that the impeller (15) is free to turn once the diffuser screws (20) are fully tightened.
11. Lubricate the diffuser O-Ring (21) and the larger seal plate O-Ring (28) with silicone lubricant or Murphy® Oil Soap. This will allow the O-Rings to slip into place without getting pinched. Ensure that the big seal plate O-Ring (28) is properly seated on the large diameter of the seal plate (13).
12. Carefully slip the motor end assembly into the housing (22) pushing it forward as far as possible until the large seal plate O-Ring (28) comes into contact with the housing (22). Insert the four 6 ½ in. long screws (11) through the housing (22) and secure the assembly in place using the washers (12) and nuts (23). Gradually tighten each of the four screws a few turns in a crossing pattern to ensure that the motor assembly is properly centered to the housing. Do not over tighten these screws.

⚠ CAUTION — Failure to follow the above assembly procedures could cause the impeller to bind once the pump is fully assembled. It is possible to remove the strainer basket, reach through the strainer pot and spin the impeller to verify that it will rotate freely. A bound impeller may cause the motor to not start or cause the motor to draw excessive amps.

13. Secure the motor (1) to the motor supports (2).
14. Reconnect the ground and supply conductors.
15. Read and follow the instructions under Section 4, Initial Operation of Pump before putting the pump back into service.

Section 7

Troubleshooting

Use the following troubleshooting information to resolve possible problems with your EQ Series pump.

WARNING — RISK OF ELECTRICAL SHOCK OR ELECTROCUTION.

Improperly installation will create an electrical hazard which could result in death or serious injury to pool users, installers, or others due to electrical shock, and may also cause damage to property.



1. If you are not familiar with your pool filtering system and/or heater:

- a. **Do NOT** attempt to adjust or service without consulting your dealer, or a qualified pool technician.
- b. Read the entire Installation & User's Guide before attempting to use, service or adjust the pool filtering system or heater.

Note: Turn off power to unit prior to attempting service or repair.

Problems and Corrective Actions

Problem	Corrective Action
Pump Will Not Prime	No water in Strainer Pot Lid is not tight Damaged lid O-Ring Water level below Skimmer Strainer or Skimmer Basket clogged Closed Valve in Piping System Air leak in Suction Line Pump installed more than 10 ft. above Water Level or otherwise too high for Hydraulic Conditions of Pool Plumbing System Pump Shaft rotating in wrong direction
Low Flow- High Filter Pressure	Filter is dirty Restriction in Filter Line
Low Flow- Low Filter Pressure	Strainer or Skimmer Basket clogged Clogged Impeller Air leak in Suction Line Restriction in Suction Line Cavitation - NPSHA less than NPSHR Pump Shaft rotating in wrong direction
Motor Does Not Turn	Power Switch is off Circuit Breaker has tripped Thermal Protector has tripped Pump is in OFF mode of Timer Motor Shaft is locked by bad Bearing Impeller is jammed
Motor Over Heating	Electrical Supply Connections are incorrect Wiring to Pump is undersized Inadequate Voltage supplied to Site Ventilation is inadequate for Motor Voltage differential between legs of 3 Phase Circuit >5% Pump Shaft rotating in wrong direction
High Pitch OR Growling Noise coming from WET END of Pump	Air Leak in Suction Line Cavitation - NPSHA less than NPSHR A Valve, Elbow or Tee is located too close to the Suction Inlet of the Pump Pump Shaft rotating in wrong direction

Section 8

Replacement Parts

Illustrated Parts

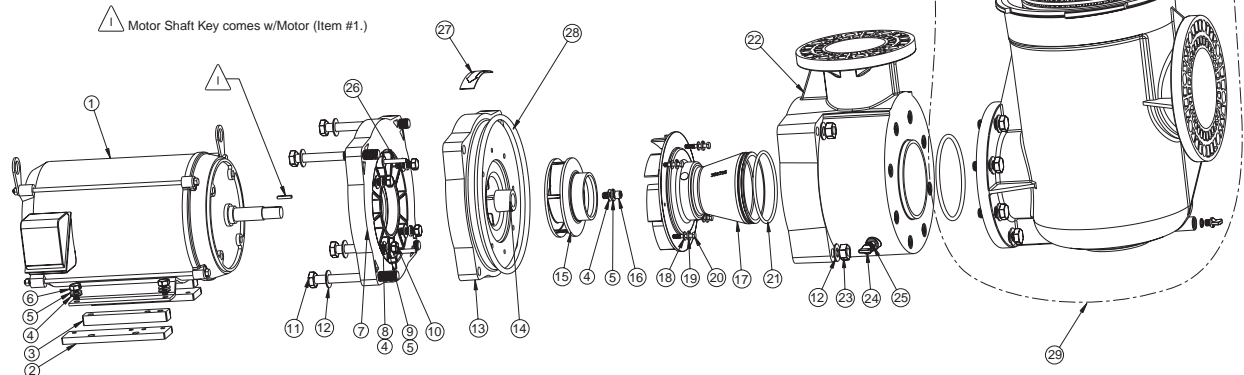

Item#	Part #	Description	Item#	Part #	Description
1	357071	Motor 15 HP 3 Phase - EQ1500 - 60 Hz	10	075843	Screw 1/2"-13 x 1 1/4" Hx Hd Cap 18-8 s/s (EQ750-1PH, EQ1000, EQ1500) - {qty. 4}
1	357070	Motor 10 HP 3 Phase - EQ1000 - 60 Hz	11	356710	Screw 5/8"-11 x 6 1/2" Hx Hd Cap 18-8 s/s - {qty. 4}
1	357069	Motor 7 1/2 HP 3 Phase - EQ750 - 60 Hz	12	356789	Washer, Flat 11/16" ID x 1-5/16" OD .078 Thk 300 s/s {qty. 8}
1	357066	Motor 7 1/2 HP 1 Phase - EQ750 - 60 Hz	13	356795	Seal Plate - EQ Series
1	357068	Motor 5 HP 3 Phase - EQ500 - 60 Hz	14	071725	Seal Set
1	357065	Motor 5 HP 1 Phase - EQ500 - 60 Hz	15	350030	Impeller Assy. - EQ500
1	357067	Motor 3 HP 3 Phase - EQW300 - 60 Hz	15	350029	Impeller Assy. - EQ750
1	357064	Motor 3 HP 1 Phase - EQW300 - 60 Hz	15	350028	Impeller Assy. - EQ1000
1	350158	Motor 5 HP 3 Phase - EQW500 - 60 Hz	15	350027	Impeller Assy. - EQW300, EQ1500
1	350159	Motor 5 HP 1 Phase - EQW500 - 60 Hz	15	350070	Impeller Assy. - EQW500
1	350112	Motor Expln PF 10 HP 3 Phase - EQK1000 - 50 Hz	16	071037	Screw 3/8"-16 x 1" Sckt. Hd Cap 18-8 s/s
1	350113	Motor Expln PF 7 1/2 HP 3 Phase - EQK1000 - 50 Hz	17	350032	Diffuser - EQ500
1	350153	Motor 10 HP 3 Phase - EQK1000 - 50 Hz	17	350033	Diffuser - EQ750, EQ1000
1	350154	Motor 7 1/2 HP 3 Phase - EQK750 - 50 Hz	17	356735	Diffuser - EQW300, EQ1500
1	350155	Motor 5 HP 3 Phase - EQK500 - 50 Hz	17	357273	Diffuser - EQW500
1	350156	Motor 3 HP 3 Phase - EQK300 - 50 Hz	18	51008500	Washer, Flat 1/4" 300 s/s - {qty. 4}
2	356713	Support - Motor - {qty. 2}	19	072172	Washer Split Lock 1/4" 18-8 s/s - {qty. 4}
3	356712	Support Adapter - Motor - EQW300, EQ500, EQ750-3PH - {qty. 2}	20	350035	Screw 1/4"-20 x 1 1/2" Hx Hd Cap 18-8 s/s (EQ500, EQ750, EQ1000) - {qty. 4}
4	072184	Washer, Flat 3/8" ID x 7/8" OD .05 Thk 18-8 s/s - {qty. 5 & qty. 9}	20	356797	Screw 1/4"-20 x 1-3/4" Hx Hd Cap 18-8 s/s (EQW300, EQ1500) - {qty. 4}
5	98220600	Washer Split Lock 3/8" 18-8 s/s - {qty. 5 & qty. 9}	21	350037	O-ring Diffuser 3/16" x 4-7/8"
6	A135	Screw 3/8"-16 x 3/4" Hx Hd Cap 18-8 s/s (EQ750-1PH, EQ1000, EQ1500) - {qty. 4}	22	356755	Housing - EQ Series
6	350073	Screw 3/8"-16 x 1 1/2" Hx Hd Cap 18-8 s/s (EQ300, EQ500, EQ750-3PH) - {qty. 4}	23	356776	Nut 5/8"-11 Hx Brass - {qty. 4}
7	356790	Adapter - Motor - EQ Series	24	154699	Drain Plug
8	075842	Washer, Flat 1/2" ID x 1 1/4" OD .125 Thk 300 s/s - {qty. 4}	25	192115	O-ring Drain Plug
9	350063	Washer Split Lock 1/2" 18-8 s/s - {qty. 4}	26	350060	Pin Dowel 5/16" x 1 3/4" 18-8 s/s - {qty. 2}
10	354290	Screw 3/8"-16 x 1" Hx Hd Cap 18-8 s/s (EQ300, EQ500, EQ750-3PH) - {qty. 4}	27	350072	Label, Directional Arrow
			28	356780	O-ring Seal Plate 3/8" x 11" dia.
			29	340013	Strainer Pot, Complete EQ 6" x 6"

5 Qty. is only used on models: EQ750-1PH, EQ1000, EQ1500, EQK750, and EQK1000.

Pump Technical Data

Pump Curves

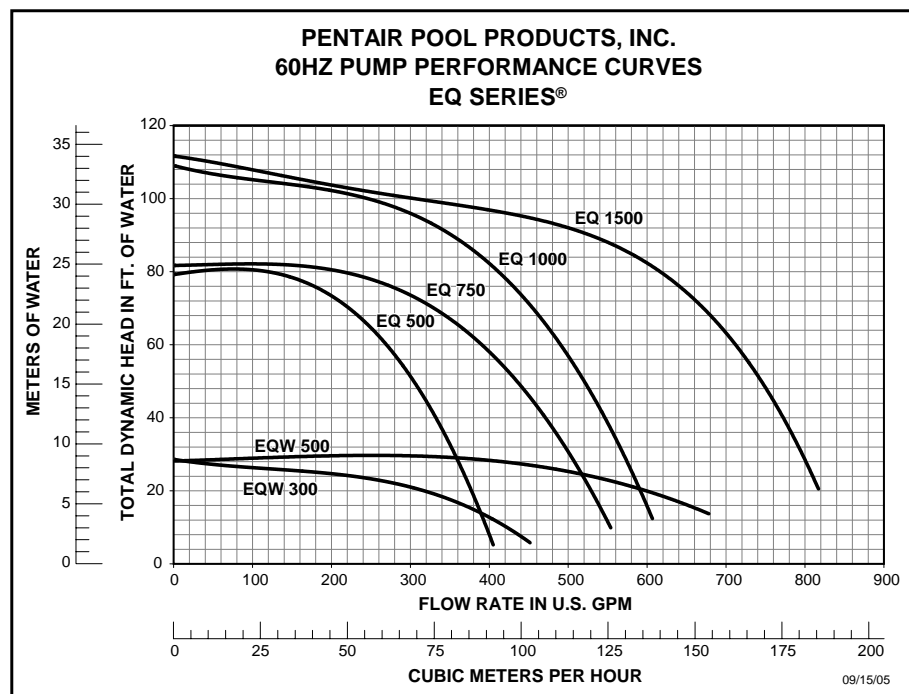
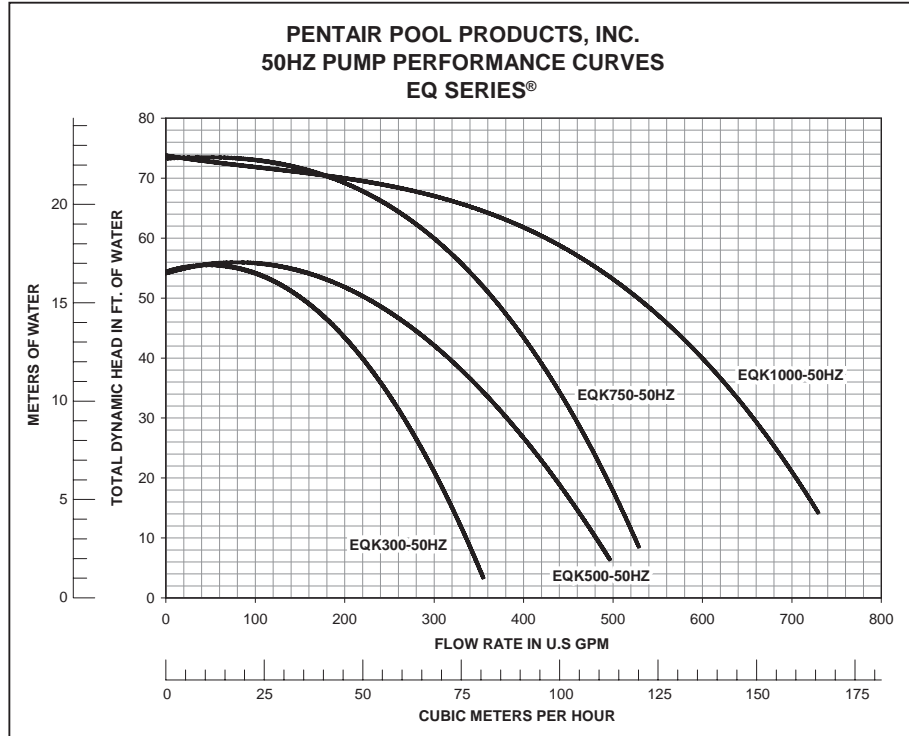

Engineering Specifications

Product No. WO Pot	Product No. WPot	Pump Model	HP	Voltage	Nameplate Amps*	Product Weight WO Strainer (lb.)*	Product Weight With Strainer (lb.)*	Dimn A* inches	Dimn B inches	Dimn C inches	Dimn D* inches
60 Hz Pump Models											
340014	340026	PUMP EQA800 - 1PH6" x4"	3	115/230	38/19	97	126	26.62	13.18	9.69	43.59
340016	340027	PUMP EQA800 - 3PH6" x4"	3	208-230/460	3.9/7.9-8.4	77	106	23.12	13.31	9.69	40.09
340017	340028	PUMP EQA500 - 1PH6" x4"	5	230	23.4	97	126	26.62	13.18	9.69	43.59
340018	340029	PUMP EQA500 - 3PH6" x4"	5	208-230/460	13.6-12.7/6.4	77	106	23.12	13.31	9.69	40.09
340019	340030	PUMP EQ500 - 1PH6" x4"	5	230	19.6	97	126	26.62	13.18	9.69	43.59
340020	340031	PUMP EQ500 - 3PH6" x4"	5	208-230/460	6.2/12.3-13.5	77	106	23.12	13.31	9.69	40.09
340021	340032	PUMP EQ750 - 1PH6" x4"	7.5	230	30.4	132	161	27.53	13.93	10.69	44.59
340022	340033	PUMP EQ750 - 3PH6" x4"	7.5	208-230/460	9.1/18.3-20.1	87	116	24.50	13.31	9.69	41.56
340023	340034	PUMP EQ1000 - 3PH6" x4"	10	208-230/460	12.2/24.3-27.1	117	146	26.31	13.93	10.69	43.29
340024	340035	PUMP EQ1500 - 3PH6" x4"	15	208-230/460	17.8/36.0-40.0	132	161	26.31	13.93	10.69	43.29
50 Hz Pump Models											
340086	340082	PUMP EQK300 - 50HZ - 3PH6" x4"	3	190/380	10.3/5.10	80	109	24.62	13.31	9.69	41.59
340085	340081	PUMP EQK500 - 50HZ - 3PH6" x4"	5	190/380	15.5/7.8	80	109	24.62	13.31	9.69	41.59
340084	340080	PUMP EQK750 - 50HZ - 3PH6" x4"	7.5	190/380	23.9/11.9	120	150	28.31	13.93	10.69	45.29
340083	340049	PUMP EQK1000 - 50HZ - 3PH6" x4"	10	190/380	30/15.1	132	162	28.31	13.93	10.69	45.29
340048	340046	PUMP EQK750 - 50HZ EXPL PF - 3PH6" x4"	7.5	190/380	23.9/11.9	120	150	28.31	13.93	10.69	45.29
340047	340045	PUMP EQK1000 - 50HZ EXPL PF - 3PH6" x4"	10	190/380	30/15.1	132	162	28.31	13.93	10.69	45.29

* This value may vary slightly depending upon motor manufacturer and motor design type.

SAVE THESE INSTRUCTIONS

Dimensional Data

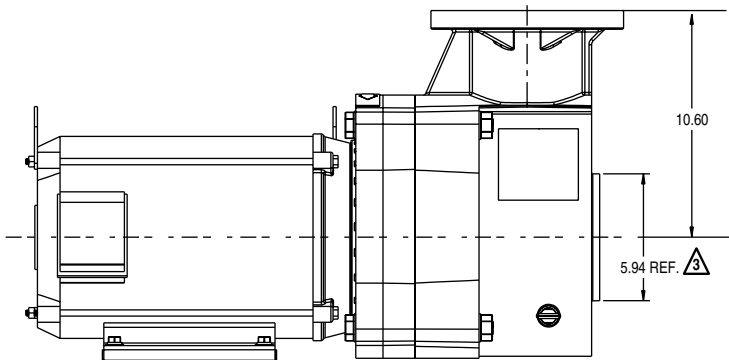
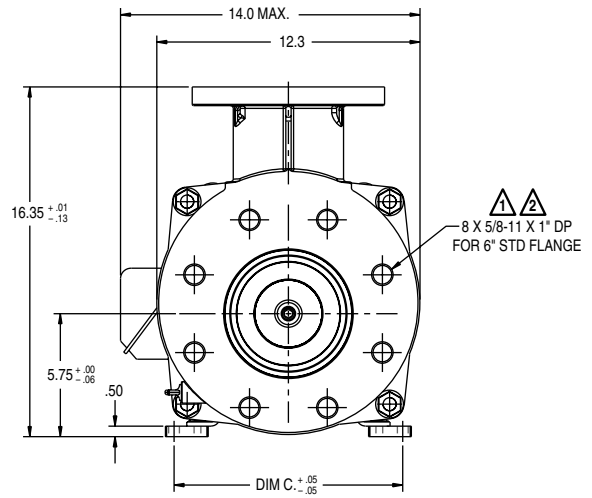
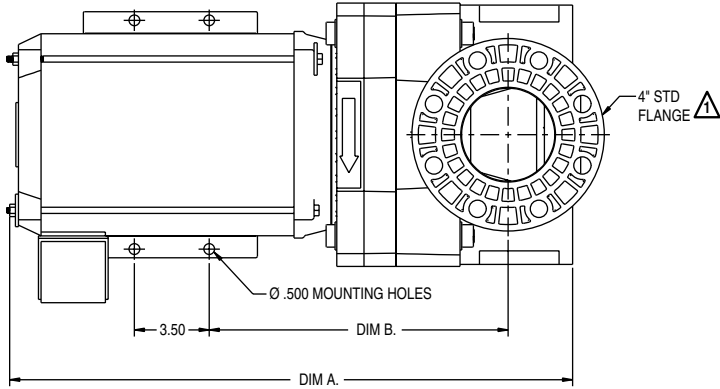

- 2 FASTENERS AND O-RING ARE INCLUDED WITH PENTAIR POOL PRODUCTS EQ 6 X 6 STRAINER TO CONNECT STRAINER DIRECTLY TO EQ SERIES PUMP. IF PUMP IS TO BE INSTALLED WITHOUT STRAINER, MAKE BOTH CONNECTIONS PER NOTE 1.
- 3 USE ANSI CLASS 150 PLASTIC FLANGE AND 1/8" THICK CLASS 150 FULL FLANGE GASKET TO MAKE CONNECTION.
- 3 THIS DIAMETER FITS INSIDE 6" SCH 40 PIPE. DO NOT USE SCH 80 PIPE AS FINAL PIPE SIZE WHEN MAKING THIS FLANGE CONNECTION.

See, **SECTION 9. PUMP TECHNICAL DATA**
 "Engineering Specifications"
 on page 19, for pump dimensions.

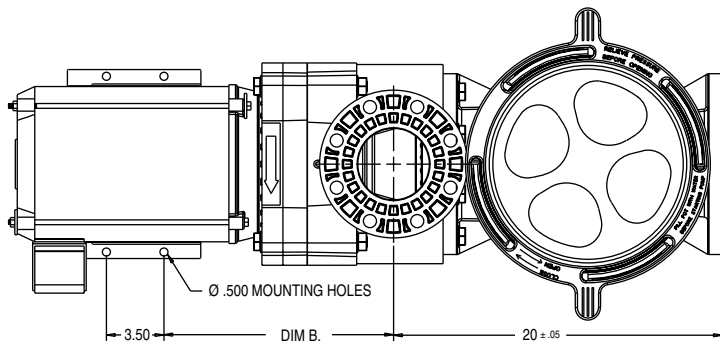

- 2 FASTENERS AND O-RING ARE INCLUDED WITH PENTAIR POOL PRODUCTS EQ 6 X 6 STRAINER TO CONNECT STRAINER DIRECTLY TO EQ SERIES PUMP. IF PUMP IS TO BE INSTALLED WITHOUT STRAINER, MAKE BOTH CONNECTIONS PER NOTE 1.
- 3 USE ANSI CLASS 150 PLASTIC FLANGE AND 1/8" THICK CLASS 150 FULL FLANGE GASKET TO MAKE CONNECTION.

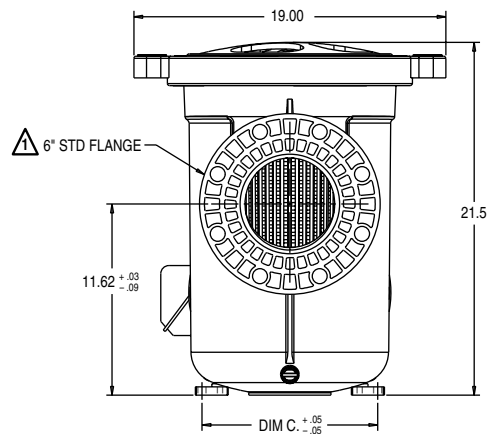
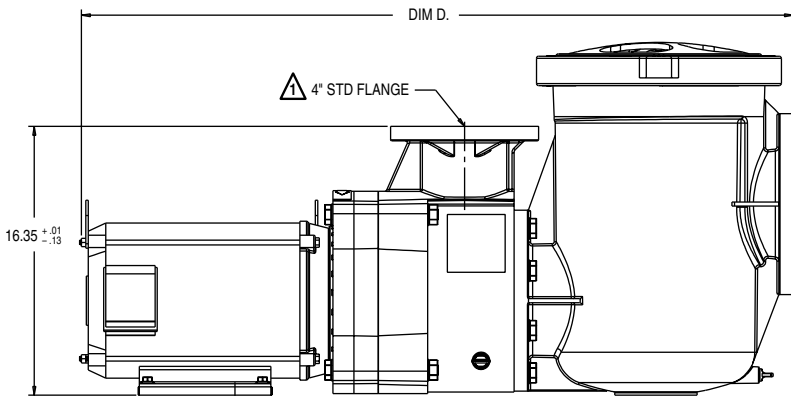

ALL DIMENSIONS ARE IN INCHES.

NOTES

